

EGOR 1018

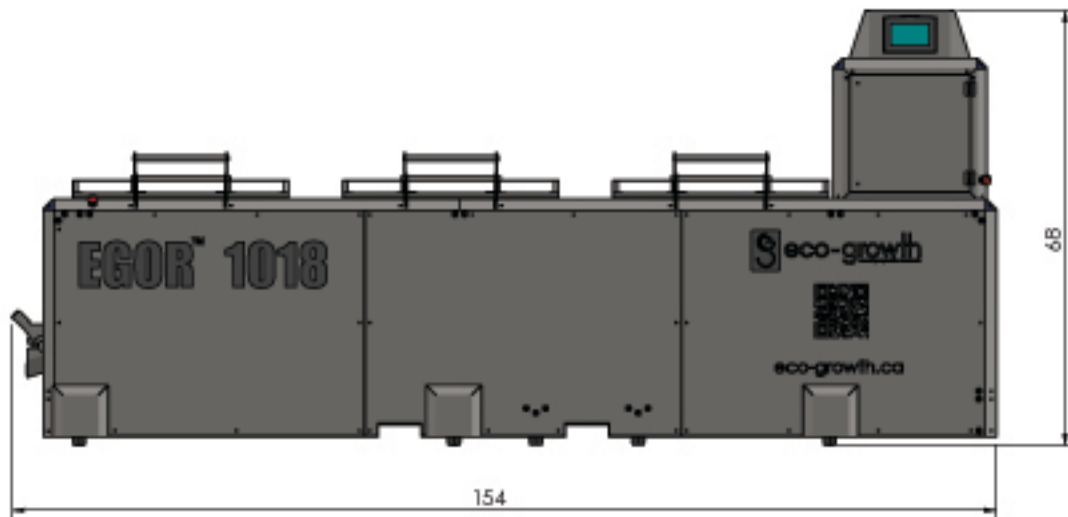
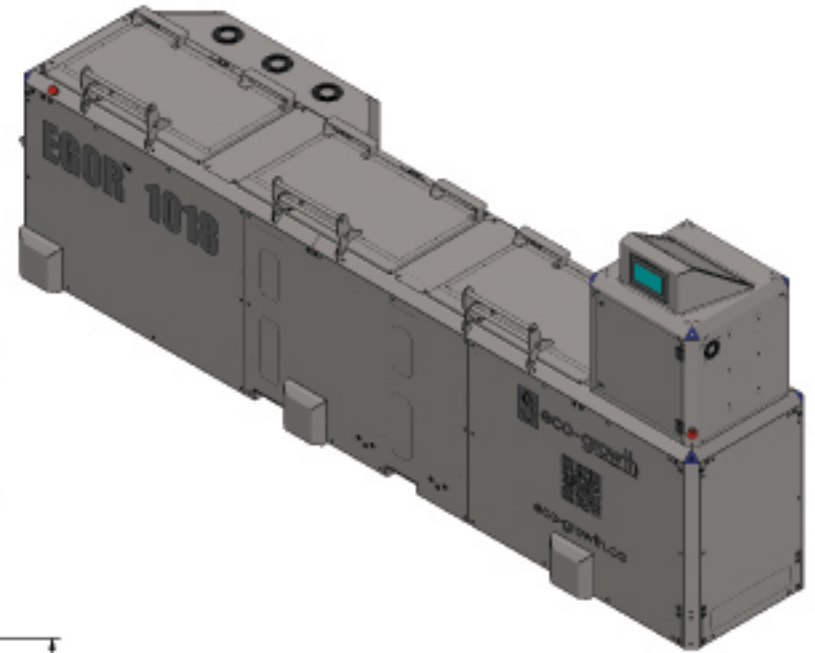
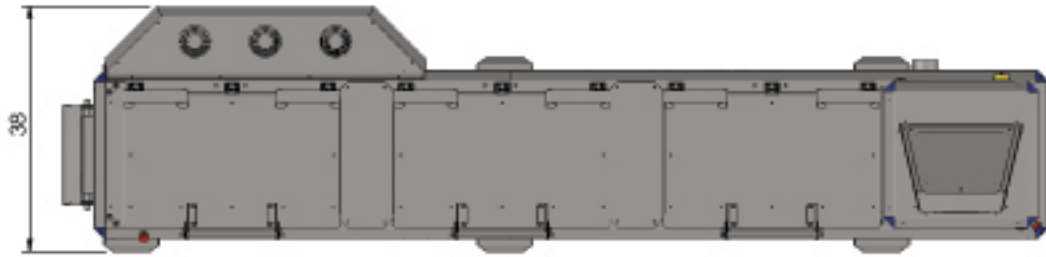

DESCRIPTION		PART NUMBER KC1018X2-MAIN ASSY	
DIMENSIONS ARE <b>INCHES</b> UNLESS SPECIFIED TOLERANCES ARE: .X = ± 0.06 .XX = ± 0.03 .XXX = ± 0.01 ANGLES = ± 1°		DRAWN BY PROVEN DESIGN WORKS LTD. PROJECT NUMBER	
WEIGHT LBS	THICKNESS (IN)	DATE	SHEET 1 OF 1
REVISION	MATERIAL	2021-05-12	

THIS DRAWING AND ALL INFORMATION THEREIN IS THE PROPERTY OF PROVEN DESIGN WORKS LTD. IT IS TO BE USED ONLY FOR THE PROJECT AND NOT TO BE REPRODUCED OR TRANSMITTED IN ANY FORM OR BY ANY MEANS, ELECTRONIC OR MECHANICAL, INCLUDING PHOTOCOPYING, RECORDING, OR BY ANY INFORMATION STORAGE AND RETRIEVAL SYSTEM. WITHOUT PERMISSION IN WRITING FROM PROVEN DESIGN WORKS LTD., NO PART OF THIS DRAWING IS TO BE REPRODUCED OR TRANSMITTED IN ANY FORM OR BY ANY MEANS, ELECTRONIC OR MECHANICAL, INCLUDING PHOTOCOPYING, RECORDING, OR BY ANY INFORMATION STORAGE AND RETRIEVAL SYSTEM.